



MC-553

LCR IN-WALL SPEAKER
Owner's Manual

Introduction

Congratulations on your purchase of a RBH Sound LCR In-wall speaker! Your speaker is the result of many years of research and development dedicated to producing high quality products for home audio and audio/video systems.

This manual contains features, setup recommendations and specifications for RBH Sound LCR in-wall speakers. It is recommended you thoroughly read through the material contained in this manual before connecting your speaker. This will ensure you have a good understanding of how to setup your speaker for optimum performance and allow for years of listening enjoyment.

Speaker Placement

In order to obtain the best possible sound from your speaker system, it is important to determine where the speakers will sound best in your listening room. Room reflections from the floor, ceiling and side walls influence the balance, imaging and overall sonic quality at the listening position. Experiment with speaker placement to determine which location offers the best overall sound.

Front Main Speakers

As a starting point, place your left and right speakers at least 7-feet apart from each other. The distance from the listening position to each speaker should be close to the distance that separates the two main speakers. The MC-553 has the unique ability to perform double-duty as both a center-channel speaker and as a main front left or right speaker for a surround sound system.

Center Channel Speaker

If two MC-553s are in dual-channel mode, the lower tweeter and woofer on each side can function as the center channel, this allows the top two woofers and tweeter on each speaker to be the front left or right channel. For situations where a dedicated center channel can be installed, three MC-553s can be used for the front left, center and right channels for an outstanding in-wall home theater system. See the wiring diagrams if you have questions.

Surround Speakers

The surrounds may be placed either above, behind or to the sides of the listening position. The listening position should be centered between the surround speakers. For best performance you may want to experiment with angling the surround speakers either towards or away from the listening position.

Subwoofer

Placement of the subwoofer will largely determine quality, quantity, and extension of the bass frequencies within your listening room. Bass frequencies are reinforced by close room boundaries. Placing the subwoofer in a corner will make the subwoofer sound louder and boost the very lowest frequencies. Placing the subwoofer away from walls will provide the least reinforcement, making the bass sound subjectively thinner than if the woofer were close to a wall. Good results can usually be obtained by placing a subwoofer along a wall 1-3 feet from a corner. Experiment with subwoofer placement and the sub-amplifier controls to achieve the proper bass balance.

Speaker Placement (continued)

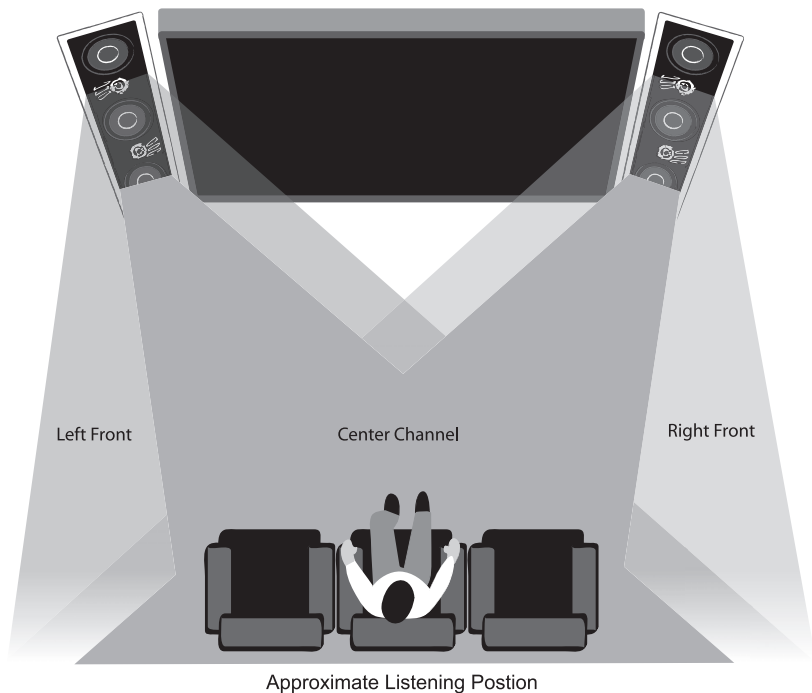

Pre-wiring the Speaker

Pre-wiring with an install bracket (optional)

1. Determine placement of speakers in the room.
2. Install the speaker bracket by nailing or stapling the wings of the speaker bracket to the studs of the wall or ceiling. The bracket has a ½-inch lip that should face into the room. This lip will provide a guide for the sheetrock installers to cut the hole for the speaker.
3. Run speaker wire from the audio equipment location to the speaker bracket. Make sure you have plenty of wire at the speaker location to connect to the speaker, three feet is recommended.
4. If you are running wire through studs, consider using nail guards to protect your wires from sheetrock nails or screws.
5. See installing the speaker on page 3 for more information.

Pre-wiring without an install bracket

1. Determine the location of the speakers.
2. Run speaker wire from the audio equipment location to the speaker location. Make sure you have plenty of wire at the speaker location to connect to the speaker, three feet is recommended.

Pre-wiring the Speaker (continued)

3. Secure the speaker wire to a framing member with a staple. If you are using a staple, be careful not to nick or pierce the wire. Make sure the wire is back far enough that the sheet rocker's blade or router will not cut it.
4. After the sheetrock or finish material has been installed, use the cutout template that came in the speaker box to cut a hole in the sheetrock. Leave the wire loose enough that you can reach into the hole you will cut into the sheetrock. Be mindful of the studs or floor joists as you place the template.
5. See installing the speaker below and the wiring diagrams more information.

Painting the Speaker Frame and Grille

When you received your speaker, a paint shield was included. This shield can be used to protect the speaker when painting the speaker rim (frame). If you plan to paint your speaker, we recommend that it be done prior to installation. If you decide to paint your speaker sometime in the future, it is best to remove them by simply reversing the speaker installation steps. When painting the speaker, the paint shields provided in the packaging must be installed in place of the grille. The grille can also be painted. Painting the speaker grille should be done with a paint sprayer set to fine. Remove the grille from the speaker, peel off the grill fabric on the back of the grille and set aside. Place the grille on a flat surface. **Do not use a brush or roller on the speaker grille as it will clog the holes**, and this will greatly reduce the sound quality of the speakers. Do not paint the grille while attached to the speaker. Be sure to remove the paint shield from the speaker and replace the grille fabric to the back of the grille before reinstalling the grille and using the speakers.

Installing the Speaker

NOTE: Remove ¼-inch of the insulation from the wires before connecting to the speaker.

1. Locate the speaker wire previously run to the speaker location and connect the speaker wire to the terminal connections on the rear of the speaker. The positive conductor connects to the red terminal and the negative conductor connects to the black terminal, refer to the wiring diagram.
2. Install the speaker into cutout hole in the wall.
3. The speaker is secured by the eight dog legs. Tighten the eight screws on the front of the speaker with a screwdriver, which will rotate the dog legs out, and pull them towards the speaker. Tighten the screws until they are snug. Do not over tighten as this may make it difficult to install the grille.
4. Be sure to remove the paint shield before placing the grille on and before using the speakers.

Wiring Diagram

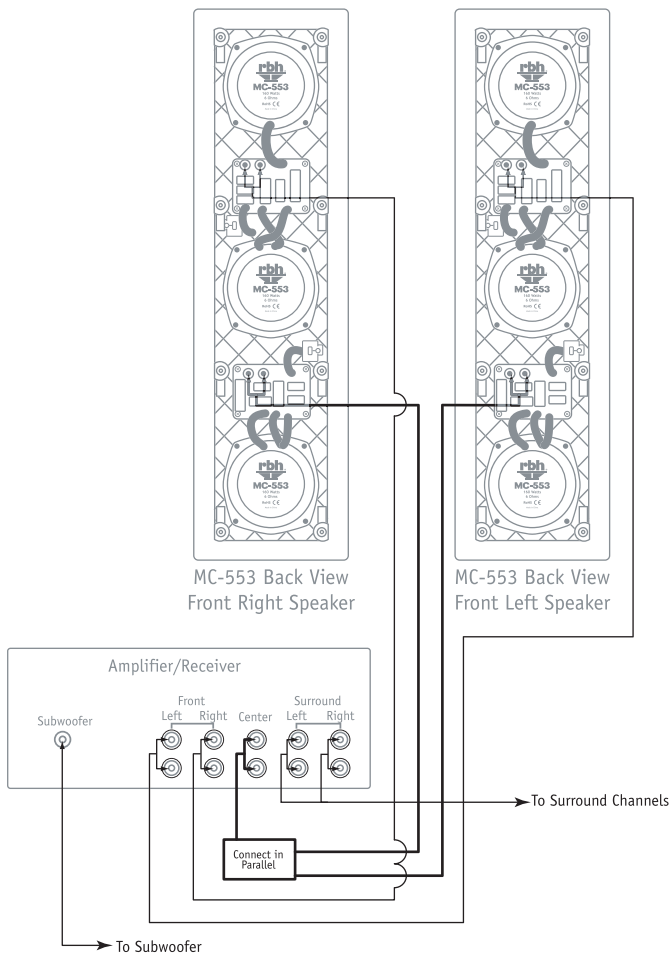

Wiring Diagram (continued)

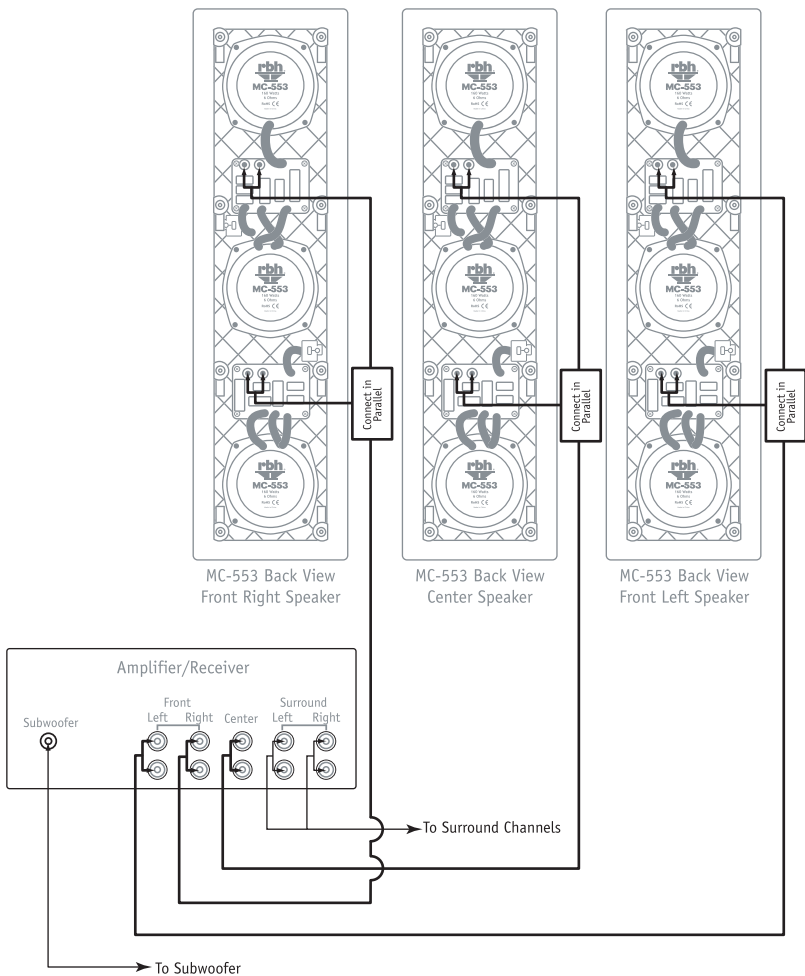

Speaker Adjustment

The MC-553 has two pivoting tweeters and a +3/0/-3 dB gain switch. To select a setting on the gain switch simply slide the switch up, down or position it to the middle to obtain the desired sound. Depending upon your listening area, you may find the sound more pleasing to point the tweeters in a particular direction. If additional treble is desired, simply point the tweeters towards that area; if less treble is required, point the tweeters away.

Gain Switch Settings:

-3dB Reduces the loudness of the treble frequencies

0dB The treble frequencies remain at a neutral level

+3dB Increases the loudness of the treble frequencies

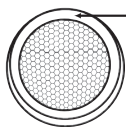

Pivot the tweeter by gently pushing on the sides of the tweeter.



Break In Period

Allow several hours of listening time to adequately break-in the speakers. As the speakers break-in, the driver suspension will loosen. The result of break-in will be an increase in low frequency response, improved definition, and increased clarity and detail.

Specifications

Model:	MC-553
Woofers:	Three 5¼" (133mm) Aluminum Cone
Tweeters:	Dual 1" (25mm) Pivoting Aluminum Dome with +3/0/-3dB switch
Impedance:	6 Ohms (in dual-mode) 4 Ohms (in single mode)
Frequency Response:	53Hz-20kHz ±3dB
Sensitivity:	91dB (1w/1m)
Crossover Frequencies:	120Hz / 3,000Hz
Cutout Dimensions:	Width: 6 ⁵ / ₈ " (168mm) Height: 26 ³ / ₄ " (680mm)
Finished Dimensions:	Width: 7 ⁷ / ₈ " (200mm) Height: 28 ¹ / ₈ " (714mm) Depth: 3 ³ / ₈ " (86mm)
Finish:	White Frame with White Grille (Paintable)
Weight:	9 lbs. (4.08 Kg)

Troubleshooting

Situation:	Probable Cause:	Solution:
No sound from speakers	Speaker wire not connected	Make sure wire is connected at both the speaker and the amplifier observing proper polarity
No sound from one speaker	Speaker selector on amplifier is not on Balance control on receiver or pre-amp is not centered Speaker wire not securely connected	Activate proper selector on amplifier Place balance control in the center Check all connections at amplifier and speakers
Very little bass and/or imaging	Speakers are wired out of phase	Check entire system for proper polarity and make adjustments as necessary

Warranty

Your RBH Sound MC-553 LCR In-wall speaker is covered by a limited warranty against defects in materials and workmanship for a period of 25 (twenty-five) years from the original date of purchase. This warranty is provided by the authorized RBH Sound dealer where the speaker was purchased. Warranty repair will be performed only when your purchase receipt is presented as proof of ownership and date of purchase. Defective parts will be repaired or replaced without charge by your dealer's store or the location designated by RBH Sound authorized to service RBH Sound products. Charges for unauthorized service and transportation cost are not reimbursable under this warranty. This warranty becomes void if the product has been damaged by alteration, misuse or neglect. RBH Sound assumes no liability for property damage or any other incidental or consequential damage whatsoever which may result from the failure of this product. Any and all warranties of merchantability and fitness implied by law are limited to the duration of this express warranty. Some states do not allow limitations on how long an implied warranty lasts, so the above limitations may not apply to you. Some states do not allow the exclusion or limitation of incidental or consequential damages, so the above limitation or exclusion may not apply to you.

Redefining The Way You Experience Sound.TM



382 Marshall Way, Layton, Utah • USA • 84041
Toll Free: (800) 543-2205 • Fax: (801) 543-3300
www.rbhsound.com